

# FORD TRUCKS 4445XD EURO6

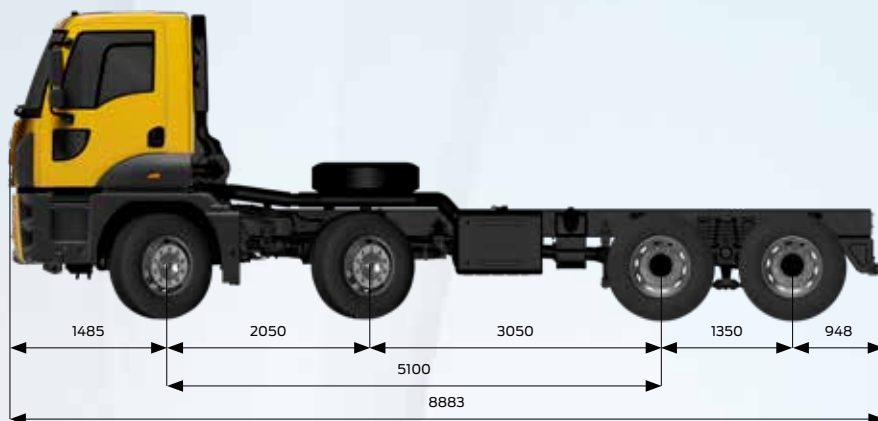

## Basic Features

|                |         |
|----------------|---------|
| Vehicle Type   | Tipper  |
| Axle           | 8x4     |
| Emission       | Euro 6  |
| Cabin Type     | Day Cab |
| Wheelbase (mm) | 5100    |

## Engine

|                    |                            |
|--------------------|----------------------------|
| Type               | Ecotorq 12.7 lt            |
| Displacement (cc)  | 12740                      |
| Diameter x Stroke  | 130 mm x 160 mm            |
| Power              | 450 PS (353 kW) / 1800 RPM |
| Torque             | 2500 Nm / 1100-1200 RPM    |
| Compression Ratio  | 17 +/- 0,5 : 1             |
| Oil Filling Volume | 50 L                       |
| Coolant Volume     | 57 L (with Intarder 77 L)  |

## Transmission

|  |                                      |
|--|--------------------------------------|
| Clutch   | 2 x 400 mm Twin Clutch               |
| Manuel Transmission / Ratios (1. gear - 16. gear)    | ZF 16S 2230 (13,805 - 0,836)         |
| Automated Transmission / Ratios (1. gear - 16. gear) | Ecotorq 16S 2600 OD (14,107 - 0,823) |

## Steering

Power Assisted Single Circuit

## Chassis

|                                 |  |
|---------------------------------|--|
| Chassis Thickness               | 10 mm with Reinforcement                             |
| Chassis Strength                | 500 MPa  |
| Suspension (Front / Rear)       | Parabolic Leaf Springs / Parabolic Tandem Suspension |
| Axle                            | Hub Reduction  |
| Axle Ratio (Manual / Automatic) | 4,87 / 4,08  |
| Tyres                           | 385/65R 22.5   |
| Wheel Rim                       | 22,5 x 11,75 Steel                                   |

## Braking System

|                           |   |
|---------------------------|---|
| Brakes (Ø mm x mm Length) | 410 x 200, Z-Cam Drum Brake System  |
| Braking System            | Dual Brake Circuit - Air Processing Unit with Integrated Oil Separator and Heater |
| Engine Brake Power        | max. 320 kW (Engine Level)  |
| Intarder Power            | max. 450 kW / Continuous 160 kW   |

## Electrical System

|                            |                     |
|----------------------------|---------------------|
| Battery                    | 24V, 2 x 12V 150 Ah |
| Alternator / Starter Motor | 130 A / 6,5 kW      |

## Tanks

|           |             |
|-----------|-------------|
| Fuel Tank | 315 L Steel |
| SCR Tank  | 55 L        |



Sharing the load

## Dimensions (mm)

|                                       |      |
|---------------------------------------|------|
| Front Overhang                        | 1485 |
| Wheelbase                             | 5100 |
| Overall Length                        | 8883 |
| Overall Vehicle Height                | 3249 |
| Overall Cab Length                    | 1827 |
| Rear Overhang                         | 948  |
| Useful Chassis Length                 | 6165 |
| Overall Vehicle Width (Excl. Mirrors) | 2540 |
| Ground Clearance - Front              | 379  |
| Ground Clearance - Rear               | 305  |

## Weights (kg)

|                                 | 1. Axle | 2. Axle | 3. Axle | 4. Axle | Total |
|---------------------------------|---------|---------|---------|---------|-------|
| Technically Permissible Weights | 9000    | 9000    | 13400   | 13400   | 44000 |
| Kerb Weight                     | 3455    | 4594    | 2021    | 1862    | 11932 |
| Payload                         | 5545    | 4406    | 11379   | 11538   | 32068 |
| GVM (Legal)                     | 8000    | 8000    | 9500    | 9500    | 32000 |

### STANDARD EQUIPMENT

- Extra Heavy Duty Features (Twin Clutch, 13R 22.5 Tyre, Fuel Tank Guard, Parabolic Tandem Suspension)
- Manuel Air Conditioner
- AM/FM/Aux In/USB/Bluetooth (Radio with Bluetooth)
- Transmission Offset (double gear) PTO without Flange
- 4 Point Independent Cab Suspension for Day Cab
- Drum Brake
- Cruise Control
- Electrically Operated Windows
- Electrically Operated and Heated Side Mirrors
- Electrically Operated Headlamp Leveling
- Rake and Reach Adjustable Steering Column
- Heated and Air Suspended Driver Seat
- Lumbar Support
- Short Bumper
- Front Vehicle Antiroll Bar
- Anti-lock Brake System (ABS)
- Brake Lining Wear Sensor
- Immobilizer
- Single Key with Remote Control and Central Locking
- Home Safe
- Approach Lights
- Differential Lock
- Digital Tachograph
- Switchable Air Compressor (For Improved Fuel Economy)
- Front Towing Hooks (Double Hook)
- Reinforced Wheel Rim
- DAB Radio\*\*
- Electro-Hydraulic Power-Assisted Steering System (EHPAS)

### OPTIONAL EQUIPMENT

- Automated Transmission (with Normal Mode, Off-Road Mode, Rocking Mode)
- Engine Driven PTO and Interior Control Unit
- Transmission Direct (Double Gear) PTO without Flange (includes Power Take off Control Unit)
- Intarder
- Auxiliary Cabin Heater (Wet Type)
- Cold Pack with Wet Type Cab Heater and 225 Ah Battery
- Electrically Operated Cab Tilting
- Oil Pan Protection
- Dual Passenger Seat \*
- Manually Operated Sunroof
- Low Roof Sleeper Cab
- Lateral Protection
- Rear Window
- Automatic Traction Control (ATC)
- Less Spare Tire
- Rear Towing Hook

\*Not available with Low Roof Sleeper Cab.

\*\*DAB Radio can be standard or optional according to the market.